

CERN. We thank G. Le Scornet for preparation of the targets, and assistance in the data processing. We are grateful for the assistance and cooperation of many persons from CERN who were helpful in the installation of this experiment.

<sup>1</sup>J. Cerny, *Ann. Rev. Nucl. Sci.* **18**, 27 (1968) and references therein. See also T. D. Thomas, G. M. Raisbeck, P. Boerstling, G. T. Garvey, and R. P. Lynch, *Phys. Letters* **27B**, 504 (1968); A. M. Poskanzer, G. W. Butler, E. K. Hyde, J. Cerny, D. A. Landis, and F. S. Goulding, *Phys. Letters* **27B**, 414 (1968).

<sup>2</sup>R. Klapisch, C. Philippe, J. Suchorzewska, C. Detraz, and R. Bernas, *Phys. Rev. Letters* **20**, 740 (1968).

<sup>3</sup>G. T. Garvey and I. Kelson, *Phys. Rev. Letters* **16**, 197 (1966).

<sup>4</sup>R. Klapisch, J. Chaumont, C. Philippe, I. Amarel, R. Fergeau, M. Salomé, and R. Bernas, *Nucl. Instr. Methods* **53**, 216 (1967).

<sup>5</sup>A secondary focus suitable for our experiment was calculated by A. E. Ball and J. M. Mauguin, CERN Report No. NPA int 69-4, 1969 (unpublished). We wish to thank these and numerous other persons of the group led by B. Langeseth who continually maintained this complex beam transport throughout our run.

<sup>6</sup>E. Beck, to be published.

<sup>7</sup>M. J. Nurmia and R. W. Fink, *Nucl. Phys.* **8**, 139

(1958); E. L. Robinson, B. T. Lucas, and E. Johnson, *Phys. Rev.* **122**, 202 (1961).

<sup>8</sup>C. M. Lederer, J. M. Hollander, and I. Perlman, *Table of Isotopes* (John Wiley & Sons, Inc., New York, 1967), 6th ed.

<sup>9</sup>A. M. Poskanzer, S. W. Cosper, E. K. Hyde, and J. Cerny, *Phys. Rev. Letters* **17**, 1271 (1966).

<sup>10</sup>C. Detraz and R. Klapisch, to be published. A detailed and critical evaluation of this argument will be published elsewhere.

<sup>11</sup>D. Kurath, private communication; S. Cohen and D. Kurath, *Nucl. Phys.* **73**, 1 (1965).

<sup>12</sup>Since the ground state of <sup>11</sup>Be is of positive parity, we assume that the transition to this state is forbidden and we identify the first excited  $\frac{1}{2}^-$  state [D. I. Auton, B. Zeidman, H. T. Fortune, J. P. Schiffer, and R. C. Bearse, *Bull. Am. Phys. Soc.* **14**, 489 (1969)] with the lower  $\frac{1}{2}^-$  calculated by Kurath.

<sup>13</sup>A. M. Poskanzer, P. L. Reeder, and I. Dostrovsky, *Phys. Rev.* **138**, B18 (1965).

<sup>14</sup>W. D. Myers and W. J. Swiatecki, *Nucl. Phys.* **81**, 1 (1966).

<sup>15</sup>C. Thibault-Philippe, R. Klapisch, and R. Bernas, to be published.

<sup>16</sup>J. Cerny, R. A. Mendelson, Jr., G. J. Wozniak, J. E. Esterl, and J. C. Hardy, *Phys. Rev. Letters* **22**, 612 (1969).

<sup>17</sup>P. M. Endt and C. Van der Leun, *Nucl. Phys.* **A105**, 1 (1967).

#### DETERMINATION OF THE GRAVITATIONAL CONSTANT $G^*$

R. D. Rose,<sup>†</sup> H. M. Parker, R. A. Lowry, and A. R. Kuhlthau

Department of Aerospace Engineering, University of Virginia, Charlottesville, Virginia

and

J. W. Beams

Department of Physics, University of Virginia, Charlottesville, Virginia 22903

(Received 4 August 1969)

A new method for measuring the gravitational constant  $G$  is described. Preliminary measurements give  $G = (6.674 \pm 0.012) \times 10^{-11} \text{ N m}^2/\text{kg}^2$  where the 0.012 represents 3 standard deviations. Furthermore there is reason to believe that with certain modifications of the apparatus and use of improved metrology techniques an increase in precision of at least one and probably two orders of magnitude will be obtained.

According to Newton's law of gravitation  $F = Gm_1m_2/d^2$ , where  $F$  is the force of attraction between any two particles of matter in the universe with masses  $m_1$  and  $m_2$ ,  $d$  is the distance between the particles, and  $G$  is the gravitational constant. The experiments of Eötvös<sup>1</sup> and others<sup>2</sup> and especially the more accurate experiments of Dicke<sup>3</sup> and his collaborators have shown that  $G$  is independent of the nature and magnitude of the attracting masses, their states of chemical combination, their temperatures, and the amount of matter placed between the attracting bodies. Con-

sequently, Newton's law is extremely reliable and  $G$  is one of the most fundamental, important, and useful constants in nature. On the other hand, although a large amount of careful work has been done by many investigators, the absolute value of  $G$  is probably not known to better than one part in 500. The values quoted in a recent analysis<sup>4</sup> of existing data give  $G = (6.670 \pm 0.015) \times 10^{-11} \text{ N m}^2/\text{kg}^2$ . The difficulty in measuring  $G$  arises primarily from the fact that the gravitational forces are relatively weak.

Probably the most precise methods of measur-

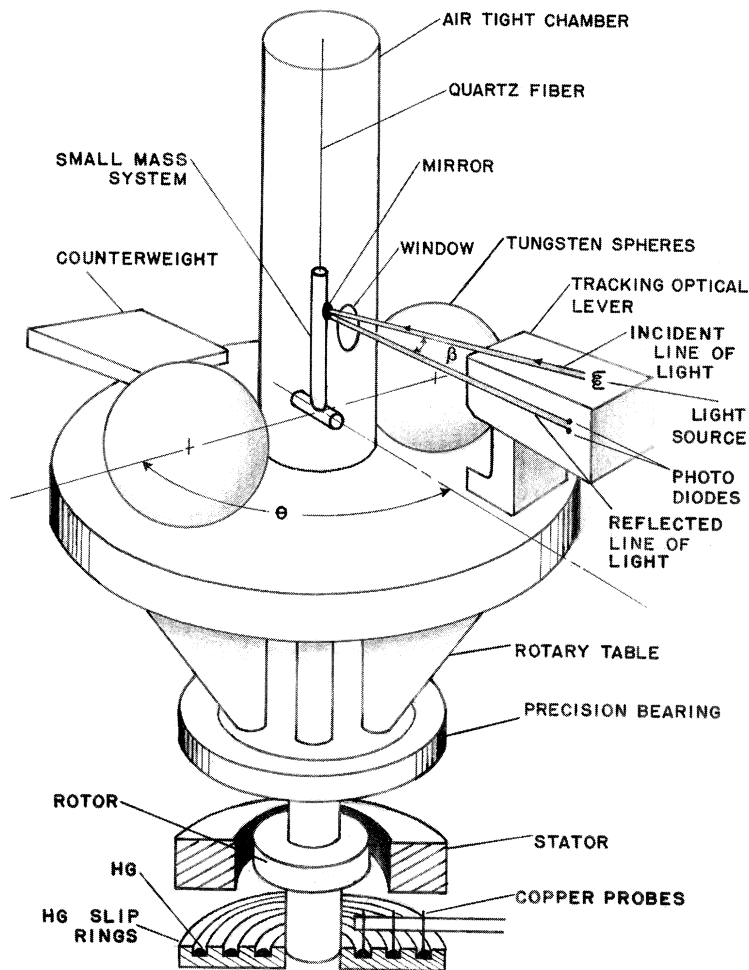

FIG. 1. Schematic drawing of experimental apparatus.

ing  $G$  have been the torsion-balance method first devised for the purpose by Mitchell and improved by Cavendish, Cornu, Boys,<sup>5</sup> and many others,<sup>2,6</sup> the "time-of-swing" method used by Heyl,<sup>7</sup> the "common balance" method of Poynting,<sup>6</sup> and the "resonance method" of Zahradnicek.<sup>2</sup> Heyl's value<sup>4</sup> is usually thought to be the most reliable determination of  $G$  that has been made to the present time. The purpose of this paper is to describe an essentially new method<sup>8</sup> of measuring  $G$  which shows promise of improved precision, and to report some of the preliminary results. Figure 1 shows a schematic diagram of the method. A small, accurately made electrically conducting cylindrical rod is suspended inside a gas-tight metal chamber by a quartz fiber rigidly attached to the top of the chamber. The chamber is mounted on top of a table which may be rotated around a vertical axis by a servomotor system actuated by an optical lever tracking device fas-

tened to the top of the table. Also on top of the table are two 10.16-cm-diam tungsten spheres mounted in such a way that their centers lie on a line passing through the axis of rotation of the table and the center of the suspended cylinder. When the angle  $\theta$  in Fig. 1 differs from zero or  $90^\circ$ , the gravitational attraction between the suspended cylinder and the tungsten spheres exerts a torque on the cylinder and it starts to rotate, i.e.,  $\theta$  starts to change. However, the tracking servo system maintains the angle  $\beta$  constant within very close limits so that  $\theta$  must remain effectively constant. As a result, the table is given a constant angular acceleration from which it is possible to determine  $G$ .

The rotary table<sup>9</sup> is rated to carry 200 lbs and has a runout of less than  $5 \times 10^{-5}$  cm at a radius of 5 cm from the axis. The table is mounted on a cement slab inside of a clean room with temperature control of  $\pm 0.5^\circ\text{C}$ . The servomotor con-

trol system has been described<sup>10</sup> in detail and the optical tracking lever (lenses were omitted in Fig. 1) is similar to the one described by Jones and Richards.<sup>11</sup> The tracking error was less than  $\pm 1$  sec of arc. The large spheres, composed of high-density tungsten, were made at the Y-12 plant at Oak Ridge.<sup>12</sup> They are spherical to better than  $12 \times 10^{-6}$  cm and have masses of  $10.48998 \pm 0.00007$  kg and  $10.49025 \pm 0.00007$  kg, respectively. The mass-center dislocation from the geometrical center is less than  $7 \times 10^{-4}$  cm. Each sphere rested on a three-point mount which in turn was supported by a common quartz plate. The distance of each sphere from the axis of rotation was measured by standard procedures and was roughly 12 cm. The small-mass system had a moment of inertia of  $4.1$  g cm<sup>2</sup> and was supported by a  $25\text{-}\mu$  quartz fiber 33 cm long. The cylinder was  $3.8100 \pm 0.0005$  cm long and  $0.3175 \pm 0.0005$  cm in radius and was made from aluminum alloy. The metal chamber was filled with helium atmospheric pressure. The time required for each revolution of the table was determined by an optical-lever, quartz-oscillator timing system which is reliable to better than  $1$   $\mu$ sec. In most of the experiments the rotating system was started from rest with the spheres in place and the angle  $\theta \cong 45^\circ$ . The acceleration turned out to be between  $4$  and  $5 \times 10^{-6}$  rad/sec<sup>2</sup>, i.e., it required about 30 min to make the first revolution and 2 h to reach 0.5 rpm. After the desired speed was reached and the acceleration determined, the tungsten spheres were carefully removed and the residual acceleration due to the small twist in the quartz fiber, etc., was measured. This was usually about  $0.1 \times 10^{-6}$  rad/sec<sup>2</sup>. From these two values the acceleration due to the spheres alone was determined. In one of the experiments, the table was given an initial negative angular velocity so that the gravitational interaction reduced the magnitude of the angular velocity. This had no significant effect on the value of  $G$ . Magnetic shielding also had no observable effect.

The times for successive revolutions were used to calculate average angular velocities over successive revolutions. These were then used to calculate angular accelerations on the assumption that the acceleration was constant. Constancy of the acceleration was the criterion of good data and was achieved only after a starting transient of, typically, an hour. Precision measurements of physical dimensions and geometry were not made, though such measurements are anticipated. For these preliminary results the various

lengths in the expression for  $G$  were measured to accuracies on the order of one part in a few thousand. The recent effort has been to obtain good, constant accelerations.

Analysis of recent experiments yields the value  $G = (6.674 \pm 0.012) \times 10^{-11}$  N m<sup>2</sup>/kg<sup>2</sup>, where 0.012 represents 3 standard deviations. Actually, all of the values fall within less than 2 standard deviations or  $\pm 7 \times 10^{-14}$  N m<sup>2</sup>/kg<sup>2</sup> which also agrees well with a probable error analysis of the parameters involved. It is observed that our value is in agreement with that found by Heyl. These preliminary measurements indicate that the method can yield much more accurate results. It was found in each of the experiments that the accuracy with which  $G$  could be measured was limited by the tracking noise produced by the variation in the friction of the bearing which supported the rotating table. A new air-bearing-supported rotary table has been obtained which possesses much less friction and requires considerably less power. Also, it is planned to replace the quartz fiber suspension with a magnetic suspension<sup>13</sup> which is essentially friction free. We are encouraged to believe that, with these and other changes, the precision in the experimental determination of  $G$  can be increased by at least one and probably two orders of magnitude. It should be noted that the present method automatically eliminates the effect of all surrounding stationary masses on the measurement of  $G$ .

The authors are especially indebted to Dr. J. Senter and Mr. W. R. Towler for invaluable contributions in designing and constructing the apparatus and to Dr. J. W. Boring and Mr. J. Dickerson for much assistance. Also, they are indebted to Dr. A. G. McNish and the members of the metrology section of the National Bureau of Standards for many helpful consultations and to Mr. R. Hibbs and Mr. E. W. Bailey of the Union Carbide Company for help in obtaining the tungsten spheres.

\*Work supported by a grant from National Aeronautics and Space Administration.

†Presently at Department of Physics, U. S. Air Force Academy.

<sup>1</sup>R. v. Eötvös, D. Pekar, and E. Fekete, *Ann. Physik* 68, 11 (1922).

<sup>2</sup>F. C. Champion and N. Davy, *Properties of Matter* (Blackie and Son Limited, Glasgow, Scotland, 1959), 3rd ed.

<sup>3</sup>R. H. Dicke, *The Theoretical Significance of Experimental Relativity* (Gordon and Breach Publishers, Inc.,

New York, 1964), pp. 3-13.

<sup>4</sup>Recommended Unit Prefixes; Defined Values and Conversion Factors; General Physical Constants, National Bureau of Standards Miscellaneous Publication No. 253 (U. S. Government Printing Office, Washington, D.C., 1963).

<sup>5</sup>C. V. Boys, Phil. Trans. Roy. Soc. (London), Ser. A **186**, 1 (1895), and Proc. Roy. Inst. Gt. Brit. **14**, 353 (1894).

<sup>6</sup>J. H. Poynting, "Gravitation," in Encyclopedia Britannica, 11th ed., and Collected Scientific Papers (The Macmillan Company, New York, 1920).

<sup>7</sup>P. Heyl, J. Res. Natl. Bur. Std. (U.S.) **5**, 1243 (1930); P. Heyl and P. Chrzanowski, J. Res. Natl. Bur. Std.

(U.S.) **29**, 1 (1942).

<sup>8</sup>J. W. Beams, A. R. Kuhlthau, R. A. Lowry, and H. M. Parker, Bull. Am. Phys. Soc. **10**, 249 (1965).

<sup>9</sup>Procured from Micrometrical Division of Bendix Company.

<sup>10</sup>W. R. Towler and E. V. McVey, to be published.

<sup>11</sup>R. V. Jones and J. C. S. Richards, J. Sci. Instr. **36**, 90 (1959).

<sup>12</sup>J. H. Nash, A. C. Neeley, and P. J. Steger, Atomic Energy Commission Research and Development Report No. Y-1654 (unpublished), Oak Ridge Y-12 Plant, Union Carbide Company Nuclear Division.

<sup>13</sup>J. W. Beams, D. M. Spitzer, and J. P. Wade, Jr., Rev. Sci. Instr. **33**, 131 (1962).

## EVIDENCE OF QUARKS IN AIR-SHOWER CORES\*

C. B. A. McCusker and I. Cairns

Cornell-Sydney University Astronomy Center, Physics Department, The University of Sydney, Sydney, Australia

(Received 3 September 1969)

In a study of air-shower cores using a delayed-expansion cloud chamber, we have observed a track for which the only explanation we can see is that it is produced by a fractionally charged particle.

It is well known that a considerable number of experiments using high-energy accelerators or low-energy cosmic radiation have failed to find the quark.<sup>1</sup> However, much higher energies occur in cosmic-ray air showers. Moreover, several groups have reported the occurrence of very large transverse momenta in interactions in these showers.<sup>2-5</sup> These momenta imply the operation of a very strong force and this might be the quark-quark interaction. Accordingly, we have looked for quarks in air-shower cores using a delayed-expansion Wilson cloud chamber.<sup>6,7</sup> In one year from July 1968 we found four tracks whose appearance was that expected for a quark of charge  $\frac{2}{3}e$ .<sup>8</sup> Several alternative explanations could be ruled out. For instance, the appearance of the tracks could not be due to a statistical fluctuation in the number of ions produced because the numbers involved were much too large. They could not be due to the Chudakoff effect because the track length at half-minimum ionization was greater than 10 cm in all cases and greater than 20 cm in one case. They could not be due to poor illumination because adjacent tracks were well illuminated. Another possible explanation of a track having half the normal specific ionization is that it is due to a particle that traversed the cloud chamber before the clearing field was removed. It would then be possible for ions of one sign to drift out of the illuminated re-

gion while ions of the other sign remained in that region. However, it is also obvious that the extra time spent in the chamber before the clearing field was removed would increase the diffusive width. In subsidiary experiments we had determined the rate of increase of the width with delay time and also measured the mean ionic mobility in the argon-alcohol-water gas mixture. Using these results we were able to show that this explanation also was unlikely.

In this Letter we report an event which we believe greatly strengthens this conclusion.

Figure 1 shows the left-hand view of a stereoscopic pair of photographs of part of event 66 240. Tracks 1 to 5 form part of a "beam" of nine parallel tracks passing through the chamber. These tracks are typical of the tracks of singly charged, relativistic particles. The diffusive widths of tracks 2, 3, 4, and 5 (measured on the original negatives with a Leitz scanning microscope with  $2\frac{1}{2}\times$  objective and  $10\times$  micrometer eyepiece) were 1.72, 1.74, 1.73, and 1.74 mm, respectively, with a standard deviation of 0.02 mm. In addition to these, we have the track labeled *R* which is parallel to the beam direction. The diffusive width of *R* is the same as the other five tracks, namely  $1.73 \pm 0.02$  mm. It is well within the illuminated region, from top to bottom of the chamber. There are well-illuminated tracks behind it, in front of it, and on both sides of it.